

## INTELLIGENT LIGHTING CONTROL SYSTEM IN LARGE-SCALE SPORTS COMPETITION VENUES

Shengmin CAO

*Physical Education Department of North-eastern University, Shenyang, Liaoning, 110819 China*  
*E-mail: 651010564@qq.com*

---

### ABSTRACT

This paper mainly studies the application of intelligent lighting control system in different sports events in large sports competition venues. We take the Xiantao Stadium, a large-scale sports competition venue in Zaozhuang City, Shandong Province as an example, to study its intelligent lighting control system. In this paper, the PID (proportion – integral – derivative) incremental control model and the Karatsuba multiplication model are used, and the intelligent lighting control system is designed and implemented by multi-level fuzzy comprehensive evaluation model. Finally, the paper evaluates the actual effect of the intelligent lighting control system. The research shows that the intelligent lighting control system designed in this paper can accurately control the lighting of different sports in large stadiums. The research in this paper has important practical significance for the planning and design of large-scale sports competition venues.

**Keywords:** intelligent lighting, control system, large sports venues

### 1. INTRODUCTION

With the development of the society, there are various kinds of sports events in the society and most of them need to be held in the stadium [1]. During the competition, the lighting management in the stadium is undoubtedly the top priority in the event management. At the same time, with the breakthrough of modern intelligent building technology, more and more buildings are beginning to in-

tegrate into various intelligent management systems [2]. As a place with huge human traffic, large sports venues will not only consume very high human resource cost, but also restrict the space for large stadiums to play their functions [3]. Therefore, an intelligent lighting control system must be introduced in it, and a more intelligent lighting management system can provide more humanized management methods and high management efficiency for the management staff of large stadiums, making the venue more energy-efficient and stable [4]. However, as the intelligent lighting control system is a new thing, the research work on it is not very rich, and the actual usage rate in the stadium of large sports is relatively low [5]. Therefore, it is necessary to carry out more and more in-depth research on the application of optical intelligent lighting control systems in different sports venues in large sports venues in order to realize the upgrade of stadium competition services [6]. Good lighting conditions are provided for the stadium to ensure that the future venue event service can be carried out normally.

### 2. STATE OF THE ART

The application of intelligent lighting control system in large-scale sports competition venues originated from the United States in the early 1980s. At that time, the United States was in the period of rapid development of information technology. Enterprises with advanced information technology at that time were not satisfied with their own fields. The development of the industry began to penetrate into other fields. The construction industry is one of

the areas where the lighting in the building is effectively controlled by computer systems, which not only enhances the lighting effect, but also reduces the power consumed by actual lighting [7]. Subsequently, Western Europe and Japan introduced such technology and developed their own lighting control system. In the 1990s, with the further improvement of technology, the technology began to transform from experimental technology to commercial technology, and Western Europe began to adopt this technology on a large scale. At that time, China's economic level was relatively backward, and did not carry out research in time [8]. In the late 1990s, with the deepening of reform and opening up and the development of social economy, it began to be studied. It was more applied in office buildings and other places, and there were few applications for large-scale sports competitions. In the 21<sup>st</sup> century, with the increase of large-scale sports venues, more and more venues have adopted this technology. Especially during the construction of Beijing Olympic Games, it is the peak of the development of intelligent lighting control system research and application [9].

### 3. METHODOLOGY

#### 3.1. PID Incremental Control Model

As early as the 1930s, researchers proposed the PID (proportion – integral – derivative) incremental control model. After years of development, its practical application in the field of industrial control has been quite rich. In the industrial control process, there are many factors that affect the control process and need to be adjusted in real time. The supporting control parameters are also constantly changing, so it is very suitable to use the PID incremental control model to control it [10]. Moreover, the development process of PID is relatively easy. In the process of being able to send, the parameters can be changed at any time according to the actual situation. It has excellent flexibility and can adapt to any actual situation. The PID incremental control model is shown in Figs. 1,3.

The PID incremental control model is a linear regulator that is the ratio (P), integral (I), and derivative (D) of the control deviation  $c = r - y$  formed by the given value  $r$  of the system and the actual

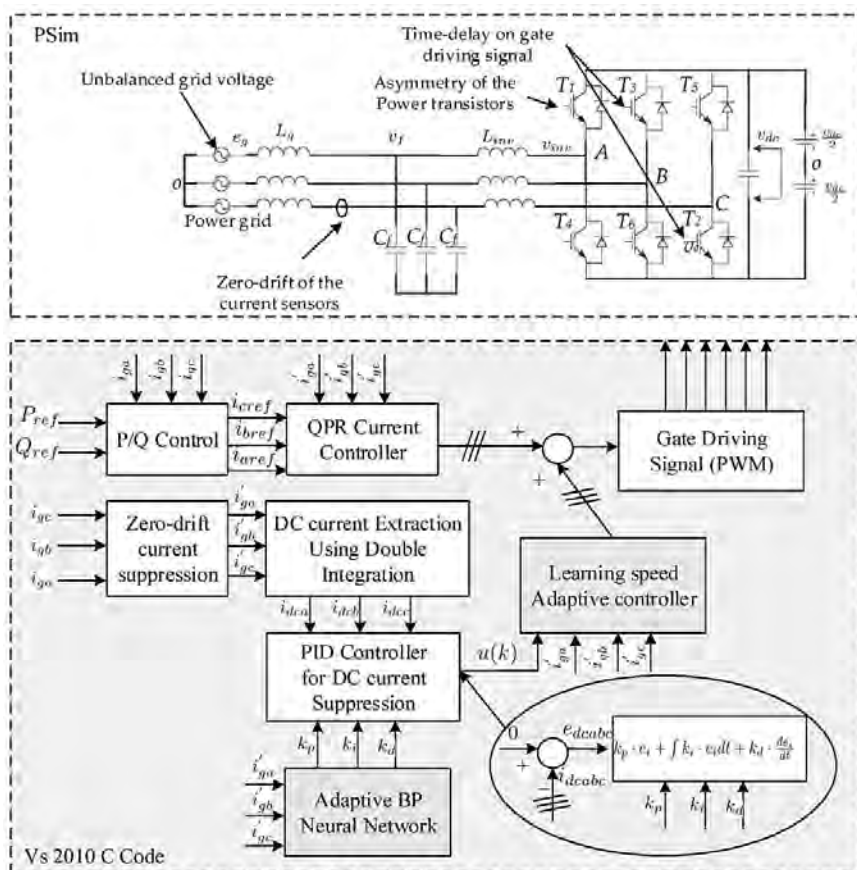

Fig.1. PID control model diagram

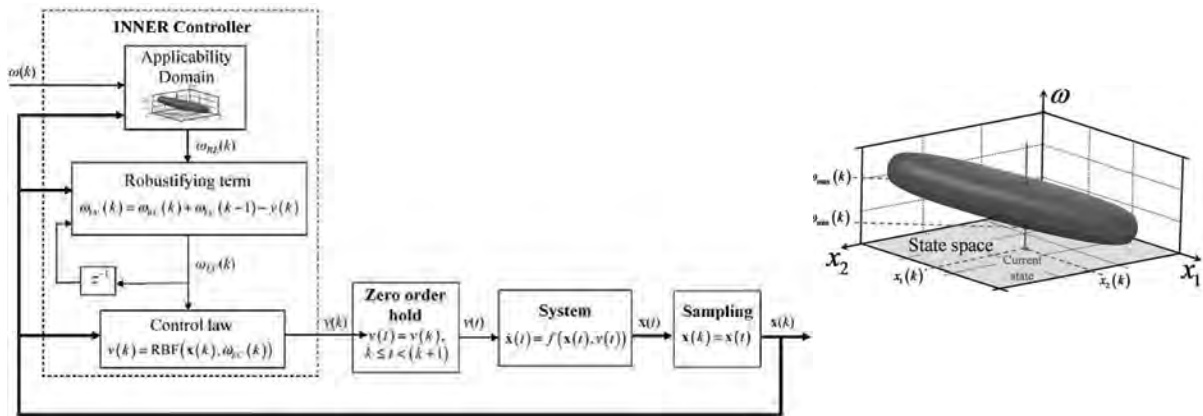

Fig.2. PID control model amplitude adjustment

output value  $y$ . The control quantity is formed by linear combination, so the PID incremental control model is abbreviated. The analogue PID control law in the continuous control system is:

$$u(t) = K_p [e(t) + \frac{1}{T_i} \int_0^t e(t)dt + T_d \frac{de(t)}{dt}], \quad (1)$$

where  $u(t)$  is the output of the algorithm,  $e(t)$  is the deviation between the system's given amount and output,  $K_p$  is the proportional coefficient,  $T_i$  is the integral time constant, and  $T_d$  is the differential time constant. Its corresponding transfer function is:

$$G(s) = K_p (1 + \frac{1}{T_i s} + T_d s). \quad (2)$$

The functions of the proportional regulator, the integral regulator and the differential regulator. The proportional regulator is used to prevent the deviation of various control parameters during the control process, which leads to the occurrence of control errors. If a control error occurs during the actual control process, the proportional regulator adjusts the control according to the corresponding principle to minimize the deviation. Proportional integral regulator: Static difference will occur during the process of proportional adjustment. In order to compensate for the control effect caused by static difference, it needs to be adjusted by proportional integral regulator. It adjusts the amount of control by deviation, and the deviation can also be accumulated. That is to say, as long as the deviation is not zero, there is adjustment. The larger the deviation, the larger the integral, the larger the ad-

justment, and the adjustment process is completed when the deviation is zero. In the actual adjustment process, in order to ensure the stability of the control, the adjustment range can be reduced by a small amount. Proportional integral differential regulators: It exists in order to make the control process complete in the shortest time. When there is a deviation in the control process, it is analyzed, and the control is adjusted according to the predicted deviation. It can minimize the adjustment range and ensure the normal operation of the system, as shown in Fig. 2.

Because of the control characteristics of the computer system itself, the deviation analysis should be carried out according to the sampling condition of the system at the time of operation. Therefore, the numerical interpolation is performed by the circumscribed rectangle method, and the first-order backward difference is numerically differentiated. When the sampling period is  $T$ ,

$$u_i = K_p [e_i + \frac{T}{T_i} \sum_{j=0}^i e_j + \frac{T_d}{T} (e_i - e_{i-1})]. \quad (3)$$

This discrete approximation is quite accurate if the sampling period is small enough. In the above formula,  $u_i$  is the full output, which corresponds to the position that the actuator of the controlled object should reach at the  $i$  sampling time. Therefore, the above formula is called the PID position type control algorithm.

It can be seen that when  $u_i$  is calculated as above, the output value is related to all past states. When the actuator does not need the absolute value of the control quantity, but the increment, the following formula can be derived:

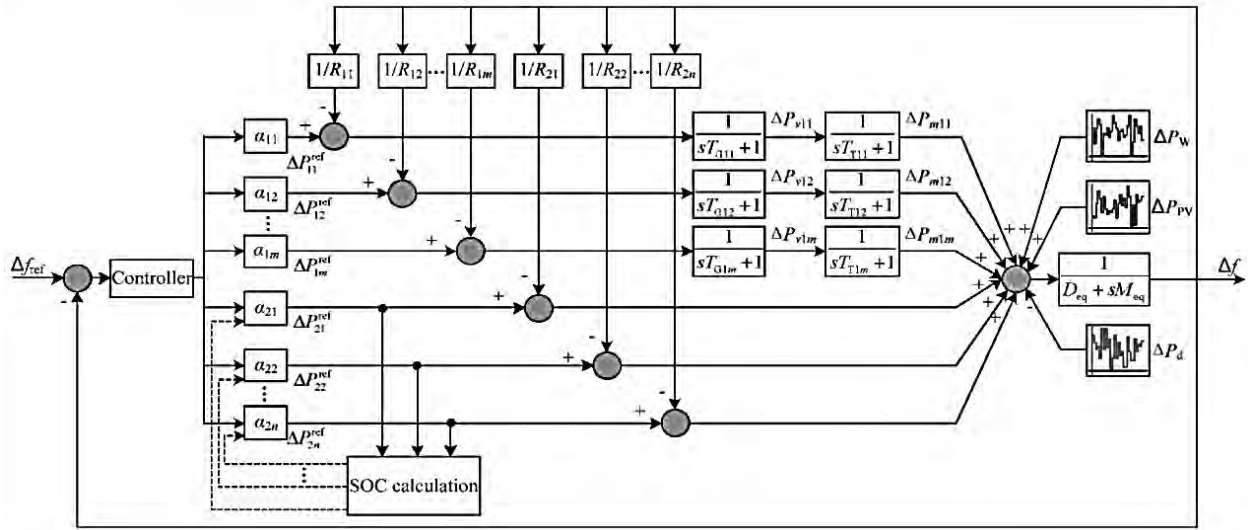

Fig. 3. Incremental PID control model circuit schematic

$$\Delta u_i = u_i - u_{i-1} = K_p [e_i - e_{i-1} + \frac{T}{T_i} e_i + \frac{T_D}{T} (e_i - 2e_{i-1} + e_{i-2})]. \quad (4)$$

$$u_i = u_{i-1} + K_p [e_i - e_{i-1} + \frac{T}{T_i} e_i + \frac{T_D}{T} (e_i - 2e_{i-1} + e_{i-2})]. \quad (5)$$

Formula (4) is called incremental PID control formula. Formula (5) is called recursive PID control formula. The quantitative control equation has the following advantages:

- The computer only outputs the control increment, that is, the change part of the actuator position, so the influence of the malfunction is small;
- The output  $u_i$  at the time  $i$  only needs to use the deviation at this moment, and the deviation  $e_{i-1}$  of the previous two moments at the previous moment,  $e_{i-2}$  and the previous output value  $u_{i-1}$ , which greatly saves memory and calculation time;
- When manual-automatic switching, the control volume impact is small, and the transition can be smoother.

The computer requirements of the control process are highly real-time. When using a microcomputer as a digital algorithm, due to the limitation of word length and operation speed, necessary methods must be adopted to speed up the calculation. The method of simplifying the formula is described below.

According to the recursive PID formula represented by the equation (6), each time the computer outputs, four additions, two subtractions, four multiplications, and two divisions are performed. If the formula is slightly combined, it is written as follows:

$$u_i = u_{i-1} + K_p (1 + \frac{T}{T_i} + \frac{T_D}{T}) e_i - K_p (1 + \frac{2T_D}{T}) e_{i-1} + K_p \frac{T_D}{T} e_{i-2} = u_{i-1} + a_0 e_i - a_1 e_{i-1} + a_2 e_{i-2}. \quad (6)$$

In the formula, the coefficients  $a_0, a_1,$  and  $a_2$  can be calculated discretely, which speeds up the operation speed of the algorithm program.

### 3.2. Karatsuba Multiplication Model

In the process of multiplying large integers, it is often encountered that the operation result overflows or the accuracy of the operation result cannot meet the requirements, as shown in Fig. 4. This also makes many fields that have stringent requirements on computational accuracy often have a variety of problems due to the operation of large integer multiplications. Therefore, how to effectively improve the calculation accuracy of large integer multiplication has become an urgent problem to be solved. In response to this problem, scholars at home and abroad have injected a lot of research energy and carried out corresponding research work.

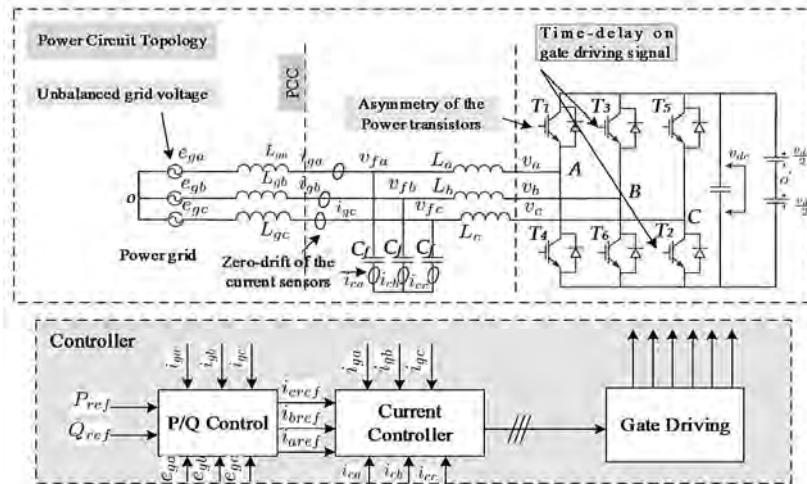

Fig.4. Big integer multiplication

In these research works, the more common methods of large integer arithmetic mainly include superposition method and divide and conquer method. The principle of the superposition method is to separate large integers and calculate them in pairs, and finally superimpose the calculated results according to different weights. The calculation idea of divide and conquer is the opposite of the superposition method. It first decomposes large integers into different small integers, then multiplies the small integers, and combines the obtained results to obtain the result of the original formula. Although the large in-

teger arithmetic method can obtain the final result of the formula, its operation efficiency is relatively low, so it is generally not used in engineering applications. For the moment, the Karatsuba multiplication model is the most widely used and most effective computational model in the process of large integer multiplication. The model mainly uses a special method of recursive method for large integer multiplication calculation, which ensures the accuracy of calculation. Under the premise, the time complexity of large integer multiplication is greatly reduced, and the operating efficiency of the al-

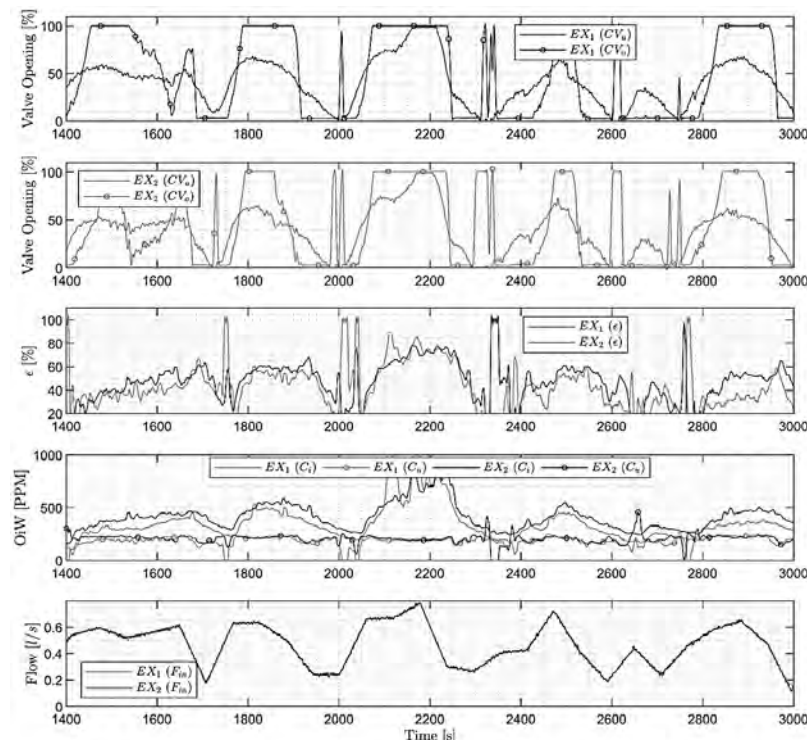

Fig.5. Karatsuba multiplication mathematical model

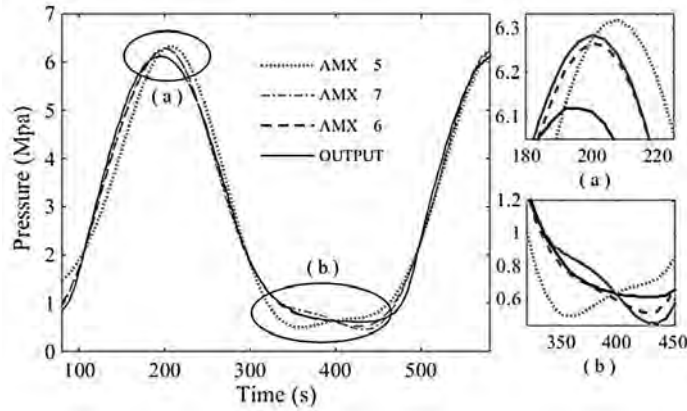

Fig.6. Karatsuba multiplication model function distribution map

gorithm is effectively improved. The mathematical implementation of the Karatsuba multiplication mathematical model (Figs. 5,6) is as follows:

According to the electromagnetic field theory, the effective value  $E_0$  of the electric field intensity from the radiation source is

$$E_0 = \frac{\sqrt{30P_T}}{d} \text{ (V/m)}. \quad (7)$$

The effective value of the magnetic field strength is

$$H_0 = \frac{\sqrt{30P_T}}{12\pi d} \text{ (A/m)}. \quad (8)$$

The electric wave power density per unit area  $S$  is

$$S = \frac{P_T}{4\pi d^2} \text{ (W/m}^2\text{)}. \quad (9)$$

If a directional antenna with a transmit antenna gain of  $G_T$  is used instead of an isotropic antenna, the above formulas should be written as

$$E_0 = \frac{\sqrt{30P_T G_T}}{d} \text{ (V/m)}. \quad (10)$$

$$H_0 = \frac{\sqrt{30P_T G_T}}{12\pi d} \text{ (A/m)}. \quad (11)$$

$$S = \frac{P_T G_T}{4\pi d^2} \text{ (W/m}^2\text{)}. \quad (12)$$

The power of the wave obtained by the receiving antenna is equal to the power density of the wave at this point multiplied by the effective area of the receiving antenna, so

$$P_R = SA_R. \quad (13)$$

Where  $A_R$  is the effective area of the receiving antenna, which satisfies the following relationship with the receiving antenna gain  $G_R$ :

$$A_R = \frac{\lambda^2}{4\pi} G_R. \quad (14)$$

In this formula,  $\lambda^2/4\pi$  is the effective area of the isotropic antenna.

Available from the above formula

$$P_R = P_T G_T G_R \left( \frac{\lambda}{4\pi d} \right)^2. \quad (15)$$

When the gain of the receiving and transmitting antenna is 0 dB, that is, when  $G_T = G_R = 1$ , the power obtained on the receiving antenna is

$$P_R = P_T \left( \frac{\lambda}{4\pi d} \right)^2. \quad (16)$$

As can be seen from the above equation, the free space propagation loss  $L_{fs}$  can be defined as

$$L_{fs} = \frac{P_T}{P_R} = \left( \frac{4\pi d}{\lambda} \right)^2. \quad (17)$$

In dB, we can know,

$$\begin{aligned} [L_{fs}](dB) &= 10\lg\left(\frac{4\pi d}{\lambda}\right)^2 (dB) = \\ &= 20\lg\frac{4\pi d}{\lambda} (dB). \end{aligned} \tag{18}$$

Or,

$$\begin{aligned} [L_{fs}](dB) &= 32.44 + 20\lg d (km) + \\ &+ 20\lg f (MHz). \end{aligned} \tag{19}$$

In the formula, the unit of  $d$  is km, and the frequency unit is in MHz.

At this point, suppose that there are  $r$  integers whose variable  $X$  and variable  $Y$  belong to  $n$  bits, and then you need to calculate the product  $XY$  of them. Then you need to segment the variable  $X$  and the variable  $Y$  first. In order to facilitate the calculation into two segments, the length of each segment is more suitable for the  $n/2$  position, as shown in the following formula.

$$X = \underbrace{A}_{n/2} \underbrace{B}_{n/2}, Y = \underbrace{C}_{n/2} \underbrace{D}_{n/2}. \tag{20}$$

Thus,  $X = Ar^{n/2} + B$  and  $Y = Cr^{n/2} + D$ . From this it can be concluded that the product of variable  $X$  and variable  $Y$  is:

$$\begin{aligned} XY &= (Ar^{n/2} + B)(Cr^{n/2} + D) = \\ &= ACr^n + (AD + CB)r^{n/2} + BD. \end{aligned} \tag{21}$$

It is not difficult to know from the above formula (21) that if wanting to obtain the calculation result of  $XY$ , the  $n/2$ -bit integer must be multiplied by 4 times and the integer addition of 3 times without exceeding the  $n$ -bit. In addition to this, two completely different carry processing is required.

At this point, variable  $X$  and variable  $Y$  can be expressed by the following formula:

$$X = x_{n-1}x_{n-2}\dots x_1x_0. \tag{22}$$

$$Y = y_{n-1}y_{n-2}\dots y_1y_0. \tag{23}$$

In order to facilitate the calculation, it can be obtained after simplification:

$$X = \sum_{i=0}^{n-1} x_{[i]} \cdot r^i. \tag{24}$$

$$Y = \sum_{j=0}^{n-1} y_{[j]} \cdot r^j. \tag{25}$$

Therefore, the calculation formula for large integer multiplication is:

$$XY = \sum_{i=0}^{2n-1} R_{[i]} \cdot r^i = \sum_{i=0}^{n-1} \sum_{j=0}^{n-1} x_{[i]} \cdot y_{[j]} \cdot r^{i+j}. \tag{26}$$

If there are constants  $C > 0, p > 0$  and  $h_0 > 0$  then,

$$\begin{aligned} T(\varphi) &= |(L - L_h)\varphi| \leq \\ &\leq Ch^p, \forall \varphi \in C^m, \forall h < h_0. \end{aligned} \tag{27}$$

Then  $L_h$  has a truncation error of  $O(h^p)$ .

Find the limit values for any smooth  $f$  and sufficiently small  $h$  in equation (27):

$$\lim_{h \rightarrow 0} T(f) = h \left| \frac{f''}{2} \right|. \tag{28}$$

After completing its approximation, the average of the forward and backward differential approximations can be found.

$$f'(x) = \frac{1}{2} \left( \frac{f(x+h) - f(x)}{h} + \frac{f(x) - f(x-h)}{h} \right) + O(h^2). \tag{29}$$

Suppose  $T(n)$  is the total number of operations required to multiply two  $n$ -bit integers. The result inferred from the above formula yields the following expression:

$$T(n) = \begin{cases} O(1) & n = 1 \\ 4T(n/2) + O(n) & n > 1 \end{cases} \tag{30}$$

This gives,

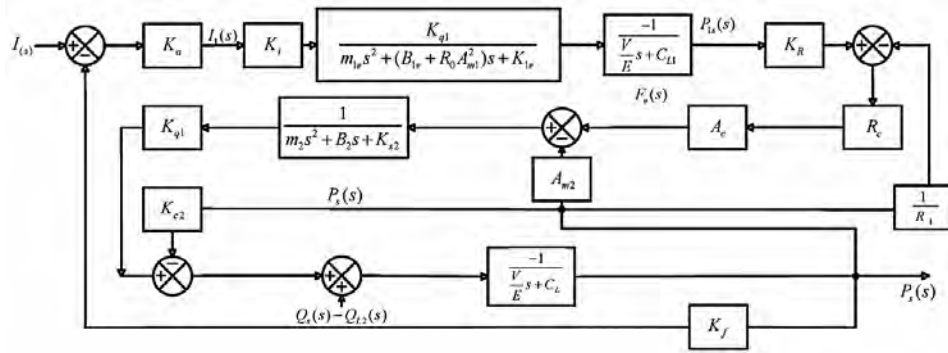

Fig.7. Lighting circuit diagram of Xiantao stadium

4. RESULT ANALYSIS AND DISCUSSION

$$T(n) = O(n^2) \tag{31}$$

In order to further improve the efficiency of the operation, it is necessary to further simplify the operation process. The product of the variable X and the variable Y obtained after simplification is calculated as follows:

$$XY = ACr^n + [(A - B)(D - C) + AC + BD]r^{n/2} + BD \tag{32}$$

With the rapid development of the IoT technology, intelligent lighting control systems have been widely used in the field of industrial control. The control principle is mainly to control different lighting sensors through smart chips to achieve the purpose of intelligent control of the lighting system. Since the real-time communication between the smart chip and different sensors needs to be ensured in the whole control process, the smart bus and the sensor are generally connected by field bus technology to achieve the effect of decentralized intelligent control (the circuit diagram is shown in Fig.7). This paper takes the Xian Tao Stadium, a large-

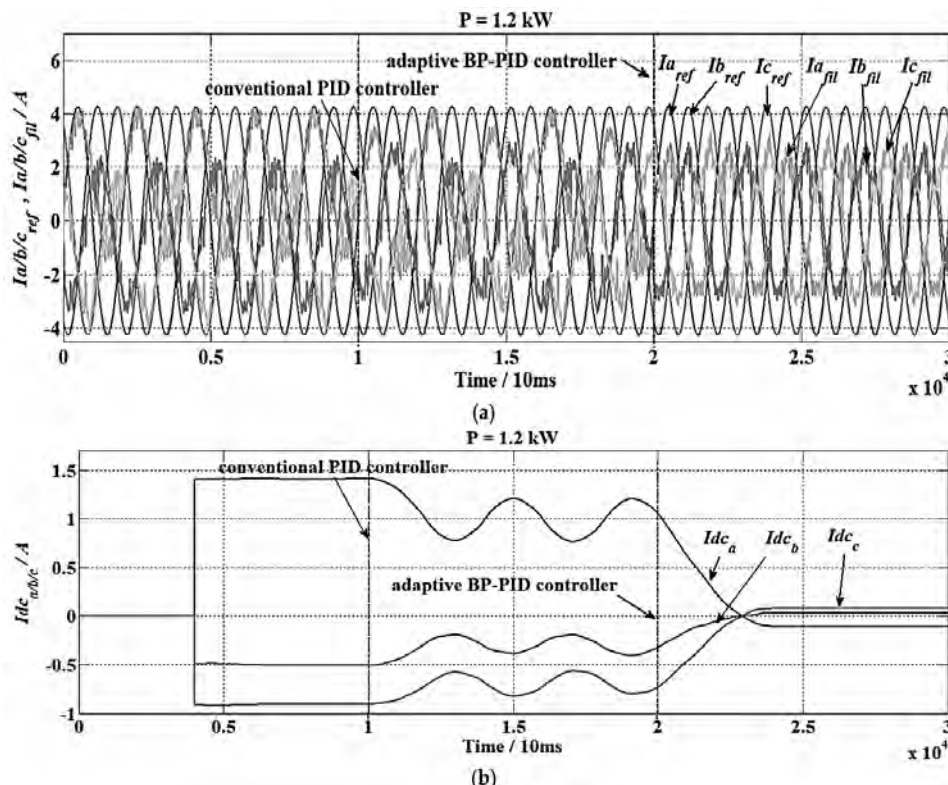

Fig.8. Intelligent lighting control system light adjustment



scale sports competition venue in Zaozhuang City, Shandong Province as a research example, and uses the PID incremental control model and the Karatsuba multiplication model to design and implement an intelligent lighting control system for different sports in large sports venues, effectively improving the quality of lighting services in large competition venues.

Xiantao Stadium is a large-scale sports competition venue newly built in Zaozhuang City, Shandong Province. It is mainly used to hold some relatively large-scale competitions. There are a number of different types of competitions in the stadium to meet a variety of competition purposes. In most cases, the venues in the stadium are multi-distributed and different competitions are carried out at the same time. This means that different types of competitions in the stadium also have different requirements for the lighting mode. The traditional lighting control mode is difficult to meet the needs of such lighting control. For this reason, using intelligent chips to design an intelligent lighting control system for centralized real-time control of the lighting of sports venues has become a future development trend.

The intelligent lighting control system designed in this paper mainly uses AT89S52 chip as the core control chip of the system. The main stadium lighting of the stadium uses 200 sets of 650W metal halide lamps for lighting control. The auditorium of the main stadium uses 36 sets of 500W iodine tungsten lamps for lighting control. The AT89S52 chip will adjust the illuminance according to the actual requirements of the different types of games. For some games with higher light perception requirements, such as table tennis competition, all the metal halide lamps will be illuminated at the same time to enhance the indoor luminosity. For some games that require an atmosphere, such as a football game, the brightness of the room light will be reduced accordingly, as shown in Fig. 8.

AT89S52 chip is a high performance and low power consumption small chip launched by STC. The chip USES key features of flash memory technology, reduces production costs, and its software and hardware are fully compatible with McS-51 related manufacturing technology, making development and testing easier and providing intelligent flexibility and cheap solutions for many embedded control systems.

Finally, the multi-level fuzzy comprehensive evaluation model is used to evaluate the actual effect of the intelligent lighting control system. The multi-level fuzzy comprehensive evaluation model is an evaluation method based on cognitive science and fuzzy mathematics. The specific form is as follows:

$$\begin{pmatrix} a_{1,1} & a_{1,2} & \dots & a_{1,n} \\ a_{2,1} & a_{2,2} & \dots & a_{2,n} \\ \cdot & \cdot & \cdot & \cdot \\ a_{n,1} & a_{n,1} & & a_{n,n} \end{pmatrix}. \tag{33}$$

In the formula,  $a_{i,j}$  represents the relative weight of indicator  $a_i$  relative to indicator  $a_j$ .

Calculate the product of each row element of the judgment matrix  $R$ ,

$$M_i = \prod_{j=1}^n B_{ij}, i = 1, 2, \dots, n. \tag{34}$$

Calculate the  $n$  root of  $M_i$ ,

$$\bar{w}_i = (M_i)^{\frac{1}{n}}, i = 1, 2, \dots, n. \tag{35}$$

Normalize  $\bar{w}_i$ , so,

$$w_i = \frac{\bar{w}_i}{\sum_{i=1}^n \bar{w}_i}, i = 1, 2, \dots, n. \tag{36}$$

Then the weight vector,

$$w = [w_1, w_2, \dots, w_k]^T. \tag{37}$$

Calculate the maximum eigen value  $\lambda_{\max}$  of the judgment matrix  $R$ , where  $[Rw]_i$  is the element of  $i$  in the  $Rw$  vector.

Let the target criterion layer weight vector obtained according to the above method be:

$$W = (w_1, w_2, w_3, \dots, w_k), \tag{38}$$

where  $w_i$  is the relative weight of the criterion layer indicator  $i$  in the criterion layer.

For the  $k$  criteria level indicators, the weights of the measures level indicators under each criterion are:

$$W_k = (w_{k1}, w_{k2}, w_{k3}, \dots, w_{kp}). \tag{39}$$

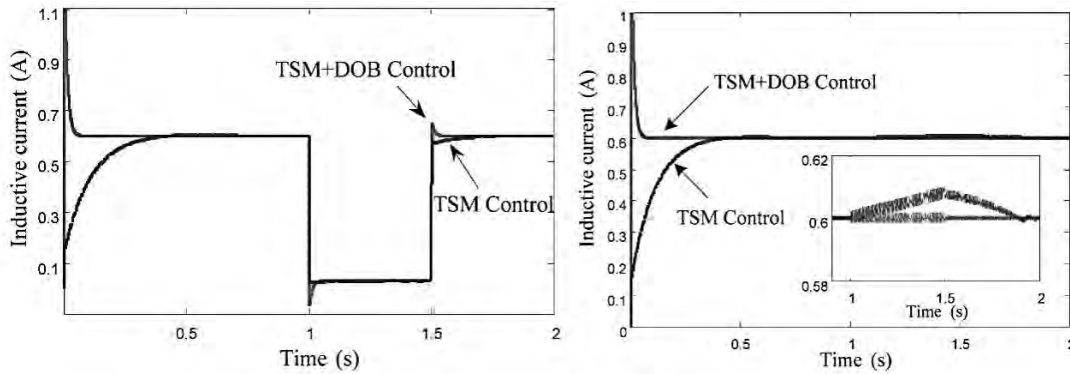

Fig.9. The program evaluation results of ocean folk sports function and development dynamic mechanism

In the hierarchical structure, the comprehensive weight calculation operator of the measure  $j$  indicator under criterion  $i$  is:

$$w_{i,j} = w_i \cdot w_j. \quad (40)$$

After obtaining the weights of the respective indicators, the evaluation score can be finally calculated by multiplying the evaluation values. The calculation operator is:

$$Ea = (w_{p,1}, w_{p,2}, \dots, w_{p,n}) (v_{p,1}, v_{p,2}, \dots, v_{p,n})^T, \quad (41)$$

where  $w_{p,i}$  is the comprehensive weight of the lowest level indicator  $i$ , and  $v_{p,i}$  is its evaluation score.

According to the content represented by the formula (41), the collected related data is substituted and the evaluation result is obtained, as shown in Fig 9. It is not difficult to see from the results that the intelligent lighting control system designed in this paper can accurately control the lighting between different sports in large sports venues.

## 5. CONCLUSION

With the development of society, there are different types of sports events in the current society and most of these events need to be carried out in large sports venues. In the course of the game, good lighting conditions are the basic guarantee for the normal operation of the game. However, unfortunately, at present, there is little research on the application of intelligent lighting control systems in sports venues. Based on the above reasons, this paper takes the Xiantao Stadium, a large-scale sports competition venue in Zaozhuang City, Shandong Province as a research example, and uses PID incremental control model and Karatsuba multi-

application model to design and realize an intelligent lighting control for different sports in large sports venues. System to effectively improve the quality of lighting services in large competition venues. The intelligent lighting control system mainly uses the AT89S52 chip as the core control chip of the system, and performs photometric control according to the actual requirements of the lighting according to different types of games. In order to verify the application effect after completing the intelligent lighting control system, this paper uses the multi-level fuzzy comprehensive evaluation model to evaluate the actual effect of the intelligent lighting control system. The results show that it is not difficult to see from the results that the intelligent lighting control system designed in this paper can accurately control the lighting between different sports in large sports venues.

## REFERENCES

1. Chi, Si D., Dongsen. Application of CAN Bus for the Intelligent Lighting Control System on Park. *Control & Automation*, 2018, V28, #1, pp.411–414.
2. Chen T. Application of Intelligent Lighting Control System to the Engineering. *China Illuminating Engineering Journal*, 2018, V25, #1, pp.70–74.
3. Guo L L. Application of Intelligent Lighting Control Technology in Lighting System for Industrial House. *Journal of Railway Engineering Society*, 2018, V59, #1, pp.116–118.
4. Dong R. An application of intelligent lighting control system in the office buildings. *Shanxi Architecture*, 2018, V4, #48, pp.69–82.
5. Cai X., Qing W U., Liu J. Constant Illumination Control of Intelligent LED Lighting Control System in Port. *Journal of Transport Information & Safety*, 2018, V20, #3, pp.281–288.

6. Dengli B U. Application of Light Sensor ISL29004 in Intelligent Lighting Control System. *Modern Electronics Technique*, 2018, V18, #7, pp.109–125.
7. Zhou W. Application of EIB Intelligent Lighting Control System in Metro. *Modern Urban Transit*, 2018, V9, #1, pp.12–13.
8. Zhang, WP., Yang, JZ., Fang, YL., Chen, HY., Mao, YH., Kumar, M. Analytical fuzzy approach to biological data analysis, *Saudi journal of biological sciences*, 2017, V2, #3, pp.563–573.
9. Zhang W., Thurow K., Stoll R. A Context-Aware mHealth System for Online Physiological Monitoring in Remote Healthcare. *International Journal of Computers Communications & Control*, 2016, V11, #1, pp.142–156.
10. Nassiopoulos, A. An Embedded PID Temperature Control Scheme with Application in a Medical Microwave Radiometer. *Journal of Engineering Science and Technology Review*, 2016, V9, #4, pp.56–60.



***Shengmin CAO,***

Doctor, Associate Professor. Graduated from the Shenyang Sport University in 1997. Worked in North – Eastern University. His research direction is the sports policy of higher education and the training of sports education