

ANALYSIS OF LED DRIVER TOPOLOGIES WITH RESPECT TO POWER FACTOR AND THD

Aniruddha Mukherjee¹, Trilok Chandra Bansal², and Amit Soni³

¹*Department of Electrical Engineering, Suresh Gyan Vihar University, Jaipur, India*

²*Department of Applied Science, Suresh Gyan Vihar University, Jaipur, India*

³*Department of Electrical and Electronics Engineering, Manipal University, Jaipur, India*
E-mail: mukherjeeanirudh73@gmail.com

ABSTRACT

Light Emitting Diodes (LEDs) are fast replacing incandescent lamps and CFLs in most of the developing nations. The reason can be attributed mainly to the enhanced lifetime and less energy consumption as compared to the other mentioned types. However one important aspect needs attention, the impact of driver on LEDs. LEDs are current controlled devices and hence emit maximum light with increase in current input to the device. This feature, boost up the light output but it increases the junction temperature of the device. Hence additional heat sinks are required to vent out the excessive heat generated due to increase current input to the LEDs. Those additional heat sinks are at times difficult to accommodate. So, designers have made arrangements to vent out the heat from the device. This is achieved by designing fins. However this arrangement is not suitable in places where the ambient temperature is more than normal. Thus, design of LED driver with controlled current input is essential in order to maintain the thermal limit of the device. Secondly, the AC-DC LEDs driver circuits, which are available in the market, are seldom equipped with input power factor and THD improvement circuitry as prescribed in IEC61000-3-2. This is essential for maintaining the energy efficiency of the nearest utility services and in addition also improves on the current drawn by the device. The following work envisages these issues and proposes corrective driver circuit based on two

different driver topologies, buck-boost topology and flyback topology. Both these topologies are proposed in order to address the aspects of power quality and its impact on the life of the device. The simulation were done using *Green Point* simulation tool from *On Semiconductors*.

Keywords: driver, junction temperature, AC-DC converter, power factor, total harmonics distortion (THD)

1. INTRODUCTION

Liu and Yang in 2009 demonstrated different driver topologies for LEDs. The work was aimed at improved performance of the device by choosing proper driver topology. In fact it defined the inherent aspect of compatibility issues of LED driver circuits with respect to the device characteristics [1].

In the year 2010 a LED driver with buck boost topology and inherent power factor correction was proposed by Aguilar. The significant aspect of the driver circuit was it was able to improve the input power factor to close to unity. The biggest disadvantages of this topology are: (a) the LED drive current is modulated at twice the utility frequency and (b) in the discontinuous mode of operation (DCM) the operation increases component stress levels thus affecting the life of the device [2,3].

In 2011, a non-isolated buck converter with power factor correction was investigated to overcome the shortcomings of the earlier proposed circuit both for continuous current and discontinuous

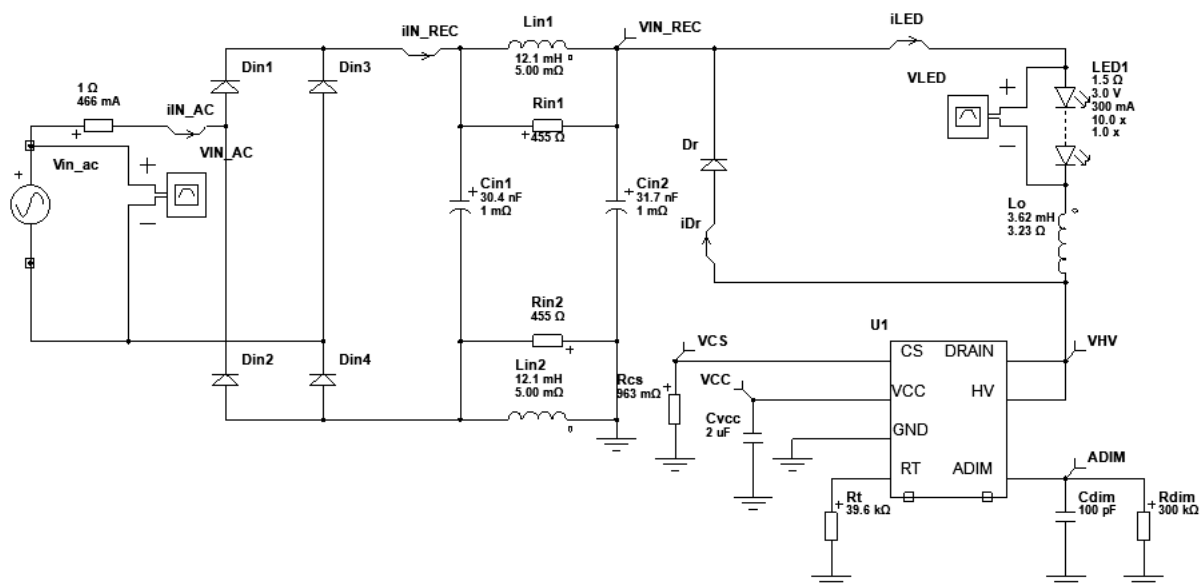

Fig.1. Proposed design of Buck Boost LED Driver using IC FLS0116

current mode of operation. In fact the proposed driver was designed for constant current drive with improved power factor. However it also increased the switching stress thus affecting the life of the LED lighting system [4].

The work done by Hu, Huber and Jovanovic in 2012 on a single-stage flyback power factor correction (PFC) circuit with a variable boost inductance for high brightness LED applications for the universal input voltage 90V-270V addressed the limitations of the conventional single-stage PFC flyback with a constant boost inductance. According to the proposed method the IEC61000-3-2 class C and corresponding Japanese standard JIS C61000-3-2 class C line-current harmonic limits were satisfied [5].

Further to this paper, the work done by Bhim Singh in 2012 deals with the PFC improved power quality based LED lamp driver. The proposed driver consists of a PFC Cuk DC-DC converter, which operates in continuous conduction mode (CCM) to improve the power quality at input AC mains [6].

In 2013 Cheng et. al. [7] has proposed a single-stage LED driver with interleaving PFC circuit for street-lighting applications. The circuit integrates an interleaved boost PFC converter with a half-bridge-type resonant converter into a single-stage converter. The presented AC-DC resonant converter uses interleaving methods to achieve input-current shaping, and possesses soft-switching functions on two active power switches to reduce

their switching losses in order to increase the circuit efficiency. The proposed LED driver features low levels of input-current ripple, reduced switching losses, high power factor, low total harmonics distortion (THD) of input current and reduced components [7].

In 2014 the work done by researchers investigated the harmonics generated from LED driver and means to mitigate it. A low pass filter is proposed to suppress the harmonics complying with the prescribed standards. Again a work done by Sreemallika in 2014 on a comparative analysis of the AC-DC Converter topologies with Active Power Factor Correction for LED applications is presented by Jettanasen and Pothisarn in 2014.

The present work emphasizes on the aspects of power factor and THD analysis in two different driver topologies: buck boost and flyback driver circuit. The proposed circuit offers a comparative study for the two different topologies for LED driver. The output waveform for both the topologies offers an insight to the life of the device. The driver circuit emphasizes on controlling the T-point temperature and controlling the current delivered to the LEDs.

1.1. Proposed driver circuit

The existing LED drivers are basically boost converter, which drives the LED with a higher voltage than specified. It is understood that the light

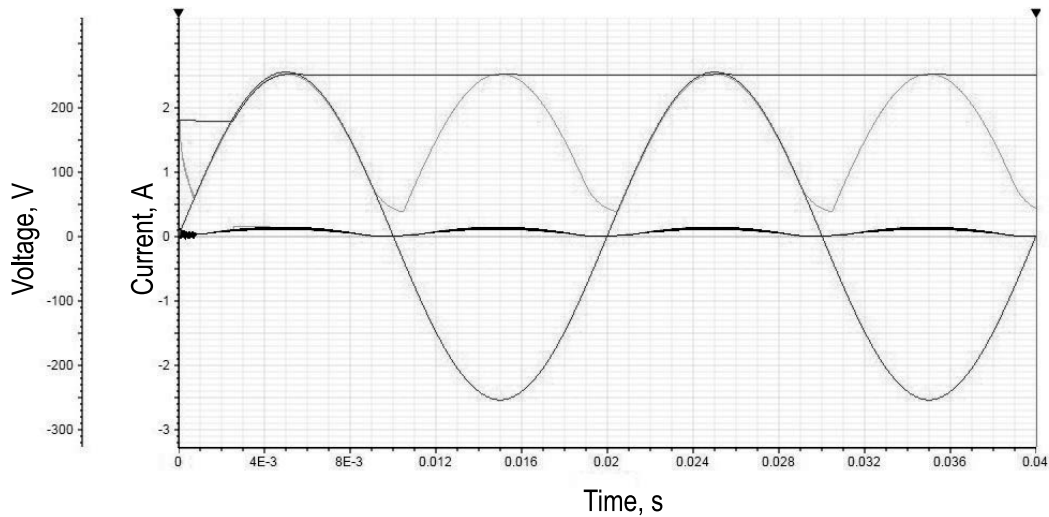

Fig.2. Input waveform of the buck boost driver

output of the LEDs is related to the current delivered to the device. In order to increase the light output, some of them drive in more current into the device thereby resulting in rise in junction temperature and, ultimately, in device failure [8–13].

The proposed design for Buck Boost converter LED driver is shown in Fig.1. The basic objective of this design is to maintain a steady output current to drive the LEDs without affecting the lifetime [8–10]. The buck boost driver has been designed without isolation from mains. This has been done because electrical insulation reduces thermal dissipation. Moreover, since heat sink is not electrically grounded, so chances of EMI generation cannot be ruled out. Further, as the electrical components are not mounted directly on the heat sink, hence the driver may be used in a non-isolat-

ed mode. The switching frequency is 50 kHz. The simulation is done through *Websim, Green Point, On Semiconductor*.

1.2. Start-up Analysis

In the successive start up analysis the input and output waveforms are observed in Fig.2 and Fig. 3 respectively. As evident from Fig.3, the output voltage varies between 16.5 V to 27.70V against the input voltage of 90V and 270V respectively. Further, from Fig.3 it is also understandable that the current varies between 0.6A to 0.8A at the input voltage of 90V and 270V respectively. The input power factor and THD analysis for the same cases are tabulated also. As observed from Table I it complies with the prescribed standards [11]. The efficiency of the dri-

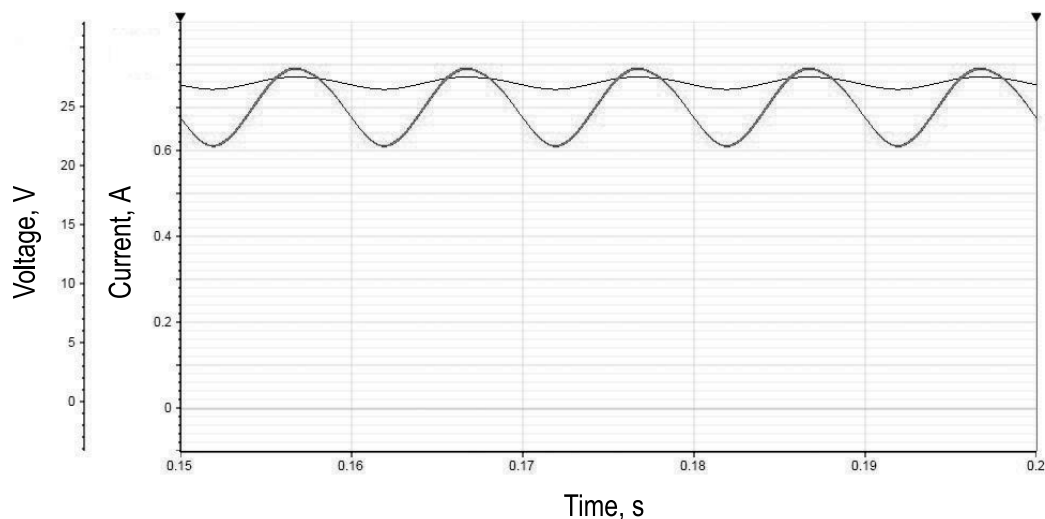

Fig.3. Output waveform of the LED buck boost driver

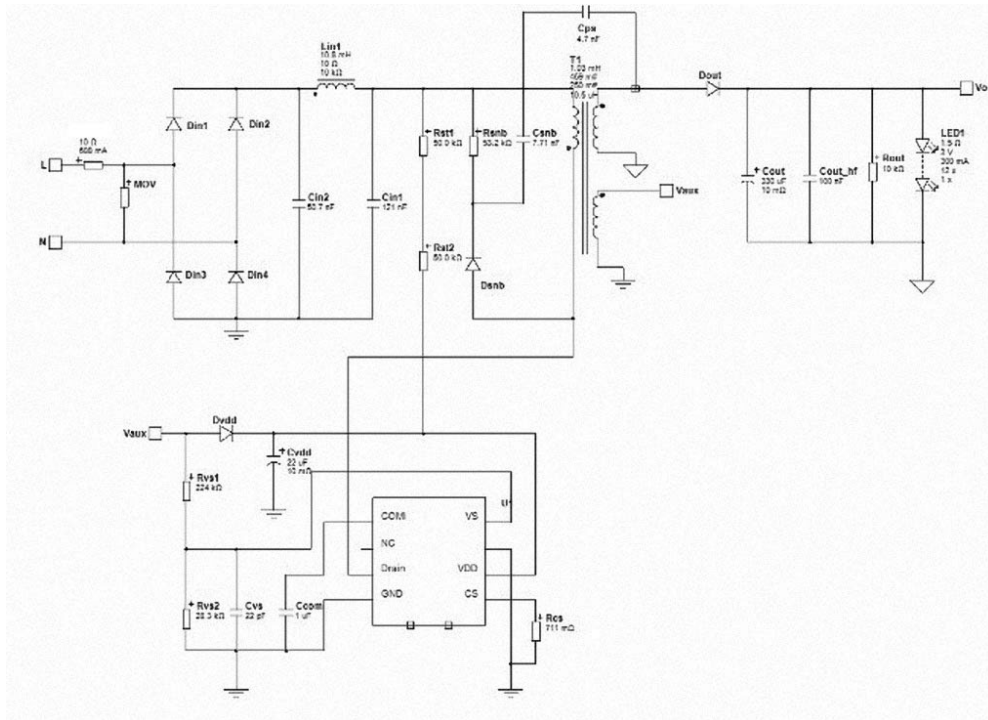

Fig.4. Proposed Flyback LED driver circuit with NCL30000

ver circuit is 84.81 %. The maximum and minimum THD_I and power factor are presented in Table I against the variable input of 90V and 270V.

1.3. LED driver- flyback topology

In the subsequent discussion the aspect Flyback type of LED driver is also simulated and analysed, Fig.4. The flyback is chosen to improve the power factor and THD within the limits as prescribed by the standards [11]. Moreover, it also aims to improve the efficiency of the system for the range of input voltage level, 90V – 270V. The THD analysis for the range of operating volatge is shown

in Table 2, Figs.5,6. As observed, the power factor at 90V is 0.998 both for low and high output. The power factor at 270V is 0.993 and 0.992 for low and high output respectively. The minimum THD_I at 90V is 6.38 % at 90V and 12.13 % at 270V. Again, the maximum THD_I is 6.9 % and 12.55 % for 90V and 270V respectively. The switching frequency is 31.6kHz. The efficiency of the driver circuit is 86.7 %.

It is observed from Table 2 that the THD content for the proposed driver and the total harmonic content is within the prescribed limits as suggested in IEC-61000–3–2 and the power factor is close to unity to be equal 0.93. This is implicative that

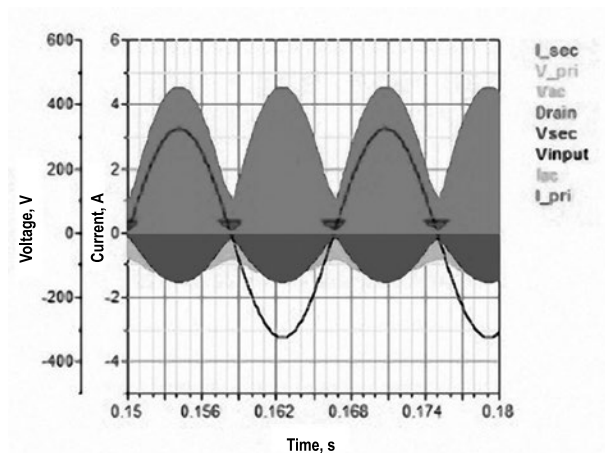

Fig.5.Input waveform of the LED flyback driver

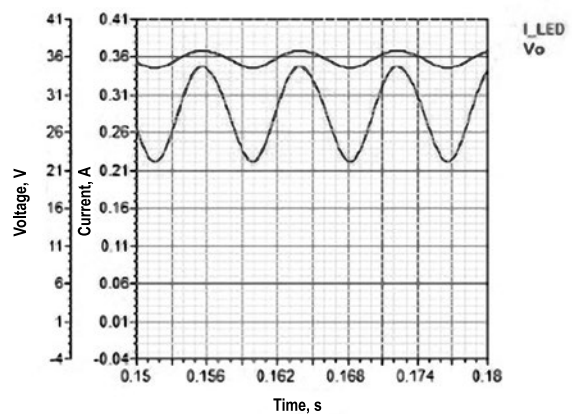

Fig.6. Output waveform of the LED flyback driver

Table 1. Power factor and THD analysis for the buck boost driver

Power Factor and THD	90V	270V
Power Factor at low Output	0.928	0.933
Power Factor at High Output	0.930	0.912
THD _{I(Min)} LEDs with full driving current	7.38 %	10.13 %
THD _{I(Max)} LEDs with full driving current	5.9 %	11.57 %

Table 2. THD analysis of flyback LED driver

Power Factor and THD	90V	270V
Power Factor at low Output	0.998	0.993
Power Factor at High Output	0.998	0.992
THD _{I(Min)} LEDs with full driving current	6.38 %	12.13 %
THD _{I(Max)} LEDs with full driving current	6.9 %	12.55 %

the current drawn by the device is not indicative of any damage to the junction temperature of the device [15–17].

2. CONCLUSION

From the above set of obtained simulation results it can be inferred that the shortcomings of the earlier design is addressed to a large extent and the driver circuit is capable of delivering power at constant current and constant voltage in the proposed buck boost driver circuit. Similarly the output current in the flyback topology is almost constant with 5 % peak to peak ripple. In addition to these the maximum and minimum T-point temperature for both the driver circuit is 40 °C and 55 °C. This protects the device from excessive rise in junction temperature and, thus, the life of the LEDs is prolonged. Moreover, the THD and harmonic content of the proposed circuit is also addressed and within the prescribed limits as per the standards [11]. With improvement in the input power factor the utility shall inject less reactive current into the system. The system efficiency is improved to a large extent and the use of LED shall not implicate the problems for a low power factor device.

REFERENCES

1. Liu Yu, Jinmin Yang, "The topologies of white LED lamps' power drivers," 3rd IEEE Conference on Power Electronics Systems and Applications (PESA), 2009, 20th–22nd May 2009, Hong Kong, pp.1–6.
2. Huang-Jen Chiu et. al., "A High Efficiency dimmable LED driver for low power lighting applications," IEEE Transactions on Industrial Electronics, Vol. 57, # 2, February 2010, pp.735–743.
3. D. Aguilar, C.P. Henze, "LED driver circuit with inherent PFC," Twenty-Fifth IEEE Annual Conference on Applied Power Electronics and Exposition (APEC) 2010, 21st–25th February 2010, Palm Springs, CA, pp.605–610.
4. Tzuen-Lih Chern et. al., "Design of LED driver circuits with single stage PFC in CCM and DCM," 6th IEEE Conference on Industrial Electronics and Applications (ICIEA) 2011, 21st–23rd June 2011, Beijing, pp.2358–2363.
5. Hu Yuequan, L. Huber, M.M. Jovanovic, "Single Stage, Universal Input AC/DC LED driver with current controlled variable PFC boost inductor," IEEE Transactions on Power Electronics, Vol. 27, # 3, March 2012, pp. 1579–1588.
6. Ashis Srivastava, Bhim Singh, "Improved Power Quality based high brightness LED lamp driver," International journal of Engineering, Science and Technology, Vol.4, # 1, March 2012, pp.135–141.
7. Chun-An Cheng et. al., "A single stage LED driver for street lighting applications with interleaving PFC feature," IEEE International Symposium on Next Generation Electronics (ISNE) 2013, 25th–26th February 2013, Kaoshiung, pp.150–152.
8. N. Narendran, J.D. Bullough, N. Maliyagoda and A. Bierman, "What is the useful life for white LEDs?" *Journal Illuminating Engineering Society*, 2001, Vvol. 30, # 1, pp. 57–67.

9. N. Narendran and Y. Gu, "Life of LED based white light sources", *IEEE / OSA Journal of display technology*, 2005, Vol.1, #.1, pp. 167–171.

10. A. Jayawardena, Yi-Wei Liu, N. Narendran, "Methods for estimating the junction temperature of AC LEDs", Council for Optical Radiation Measurements (CORM) 2012 Annual Technical Conference Ottawa, Ontario, 29 May – 1 June 2012.

11. IEC-61000-3-2, "Electromagnetic compatibility Part 3-2: Limits-Limits for harmonic current emissions", International Electrotechnical Commission, May 2014.

12. G. Meneghesso, S. Levada, R. Pierobon, F. Rampazzo, E. Zanoni, A. Cavallini, A. Castaldini, G. Scamarcio, S. Du, and I. Eliashevich, "Degradation mechanisms of GaN-based LEDs after accelerated DC current aging," in *IEDM Tech. Dig.*, 2005, pp. 103–106.

13. L. Trevisanello, M. Meneghini, G. Mura, M. Vanzi, M. Pavesi, G. Meneghesso, and E. Zanoni, "Accelerated life test on high brightness Light Emitting Diode", *IEEE Transactions on Device and Materials Reliability*, 2008, Vol. 8, # 2, pp. 304–311.

14. E.Hong, N. Narendran, "A method of projecting useful life of LED lighting systems", Third International Conference on Solid State Lighting, Proceedings of Photo-Optical Instrumentation Engineers, SPIE:5187, 2004, pp. 93–99.

15. C. H. Chen, W.L. Tsai, M.Y. Tsai, "Thermal resistance and reliability of low cost and high power LED packages under WHTOL test", *Electronics materials and packaging, EMAP2008*, Taipei, 22–24 Oct., 2008., pp.271–276.

16. G. Farkas, Q. Van Voorst Vader, A. Poppe, and G. Bogná, "Thermal investigation of high power optical devices by transient testing," *IEEE Transaction Components Packaging Technology*, 2005, Vol. 28, # 1, pp. 45–50.

17. Sujit Golder, Kalyan Kumar Ray, Saswati Mazumdar, "High Efficient DC to DC Boost Converter for White LED Based Lighting system", "*Lighting & Engineering*", 2006, Vol.14, #1, pp 53–59.



Aniruddha Mukherjee, M. Degree in engineering, he is in staff of Gyan Vihar University, and he has 18 years experience of work in field of industry and education. His field of interest is life time of different types light sources



Trilok Chandra Bansal

has spent over 45 years in the realm of academics. He did his Ph.D. in ionospheric physics. He has been associated with Gyan Vihar University as Dean Academics. He has guided many research works in the field of semiconductor physics. He is also headed many reputed scientific societies



Amit Soni, Prof., Dr.

was awarded M. Tech. and Ph.D. degree in Electrical Engineering from Malaviya National Institute of Technology (MNIT), Jaipur, India in 2005 and 2012 respectively, with specialization in "Power System". His current research field is "Solar Photovoltaic Materials and Light Emitting Diodes".

He is presently working as Professor & Head, Department of Electrical & Electronics Engineering, Manipal University Jaipur and is also actively working to find out new perspectives related to his research interest