

ON THE ISSUE OF TRANSFORMATION OF SPATIAL PHOTOMETRIC SYSTEMS

Olga E. Zheleznikova and Sergei V. Prytkov

Ogarev Mordovia State University, Saransk, Russia
E-mail: sarstf@mail.ru

ABSTRACT

Method of transition between the $A\alpha$, $B\beta$ and $C\gamma$ photometric systems are introduced on basis of their rotation adjustment in the Cartesian coordinate system and on subsequent interpolation of luminous intensity values in given nodes. This allows us to reasonably define all meridian angle values in the whole range of taken values: $[-\pi, \pi]$ for A and B , and $[0, 2\pi]$ for C .

Keywords: illumination device, photometric systems, luminous intensity curve, goniophotometry, interpolation

Spatial angular distribution of luminous intensity is defining by measurements with goniophotometer and can be prescribed in 1 of 3 photometric systems: $A\alpha$, $B\beta$, and $C\gamma$ [1, 2]. There are no strict regulations on how to select a certain system for certain light sources or illumination devices (IDs). However, there are some recommendations. According to [1, 2], spotlights should be measured in the $B\beta$ system, headlamps should be measured in the $A\alpha$ [2] system, office lamps and street lamps should be measured in the $C\gamma$ system. If the goniophotometer kinematic diagram implies a rotation of the measured discharge lamp, you should select a system that does not change the operating position of the lamp.

The case is that people often select the most measure-convenient system.

There are cases in lighting experience when you have to take photometric measurements in one system and you have to present your results in another

system. For instance, you need to compare the measuring results of 2 goniophotometers, which kinematic diagrams use different photometric systems. There are transition equations between photometric systems in [1, 2]. As you can see below, they are not totally correct.

The photometric systems are spherical coordinate systems that are specifically oriented to the first axis, the longitudinal axis, and the transverse axis of the ID [1]. The photometric systems are combined by means of either main definitions and rules of spherical geometry [3] or matrix transitions in the Cartesian coordinate system. Both methods show the same results. In this paper, we prefer the last method because of more effective and intuitive notation.

Transition from spherical coordinates to Cartesian coordinates and vice versa is accomplished as per the following equations:

$$\begin{aligned}x &= r \sin \theta \cos \varphi, \\y &= r \sin \theta \sin \varphi, \\z &= r \cos \theta,\end{aligned}\tag{1}$$

where θ is the vector angle, φ is the azimuth angle, r is the radius vector (Fig. 1).

Let us clear up the process of transition to Cartesian coordinates connected to $C\gamma$, $B\beta$, and $A\alpha$. Coordinate axes in all 3 systems are the transverse axis, the longitudinal axis, and the first axis of the ID. The positive directions of coordinate axes in $C\gamma$, $B\beta$, and $A\alpha$ define triple unit vectors $(\mathbf{i}_C, \mathbf{j}_C, \mathbf{k}_C)$, $(\mathbf{i}_B, \mathbf{j}_B, \mathbf{k}_B)$, and $(\mathbf{i}_A, \mathbf{j}_A, \mathbf{k}_A)$ (Figs. 2–4).

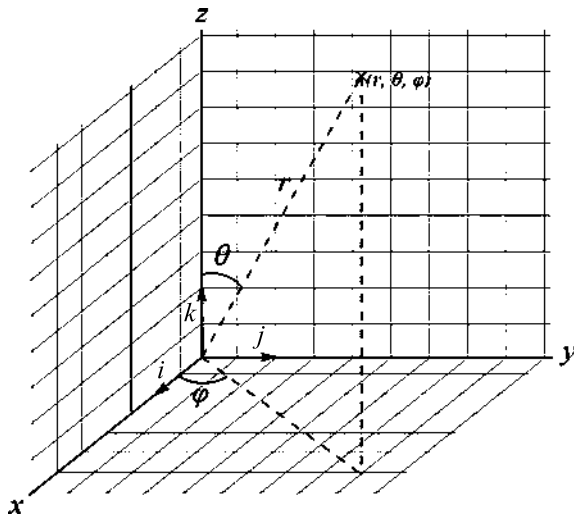

Fig. 1. Spherical coordinates system

Figs. 1–4 show that θ and φ are connected to the meridional angle and the equator angle of $C\gamma$, $B\beta$, and $A\alpha$ as follows: $\theta_C = 180^\circ - \gamma$, $\varphi_C = C$; $\theta_B = 90^\circ - \beta$, $\varphi_B = B$; $\theta_A = 90^\circ + \alpha$, $\varphi_A = A$. If we substitute the data in Eqn. (1), we get the following coordinate transition equations of $C\gamma$, $B\beta$, and $A\alpha$ to Cartesian systems:

$$\begin{cases} x_C = \sin \gamma \cos C, \\ y_C = \sin \gamma \sin C, \\ z_C = -\cos \gamma; \end{cases} \begin{cases} x_B = \cos \beta \cos B, \\ y_B = \cos \beta \sin B, \\ z_B = \sin \beta; \end{cases} \begin{cases} x_A = \cos \alpha \cos A, \\ y_A = \cos \alpha \sin A, \\ z_A = -\sin \alpha. \end{cases}$$

Now we have to rotate the coordinate axes or the basis of the systems. Referring to Figs. 2–4: at

$C\gamma \rightarrow B\beta$, rotation to \mathbf{j}_C is 270° counter-clockwise; at $B\beta \rightarrow A\alpha$, rotation to \mathbf{i}_B is 270° counter-clockwise. These are the transition data matrices:

$$R_{cb} = \begin{pmatrix} \cos 270^\circ & 0 & \sin 270^\circ \\ 0 & 1 & 0 \\ -\sin 270^\circ & 0 & \cos 270^\circ \end{pmatrix} = \begin{pmatrix} 0 & 0 & -1 \\ 0 & 1 & 0 \\ 1 & 0 & 0 \end{pmatrix};$$

$$R_{ba} = \begin{pmatrix} 1 & 0 & 0 \\ 0 & \cos 270^\circ & -\sin 270^\circ \\ 0 & \sin 270^\circ & \cos 270^\circ \end{pmatrix} = \begin{pmatrix} 1 & 0 & 0 \\ 0 & 0 & 1 \\ 0 & -1 & 0 \end{pmatrix}.$$

As you can see below, these 2 matrices are enough to completely describe the relations of the photometric systems. Let us give a matrix designation to these transitions:

$$c = \begin{pmatrix} x_C \\ y_C \\ z_C \end{pmatrix}, b = \begin{pmatrix} x_B \\ y_B \\ z_B \end{pmatrix}, a = \begin{pmatrix} x_A \\ y_A \\ z_A \end{pmatrix}.$$

The transition between the photometric systems should be described as follows:

$$C\gamma \rightarrow B\beta : b = R_{cb}c, \tag{2}$$

$$B\beta \rightarrow A\alpha : a = R_{ba}b, \tag{3}$$

$$C\gamma \rightarrow A\alpha : a = R_{ba}R_{cb}c = R_{ca}c, \tag{4}$$

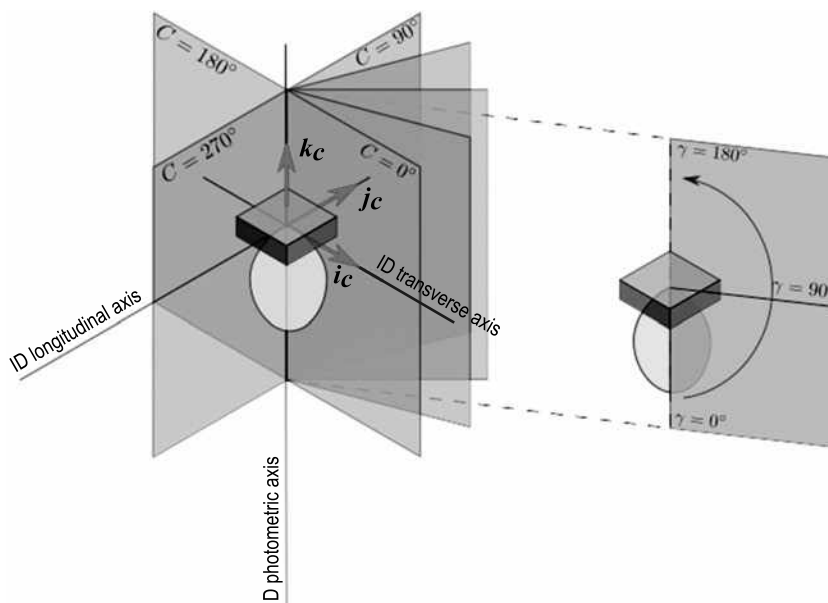

Fig. 2. $C\gamma$ photometric system

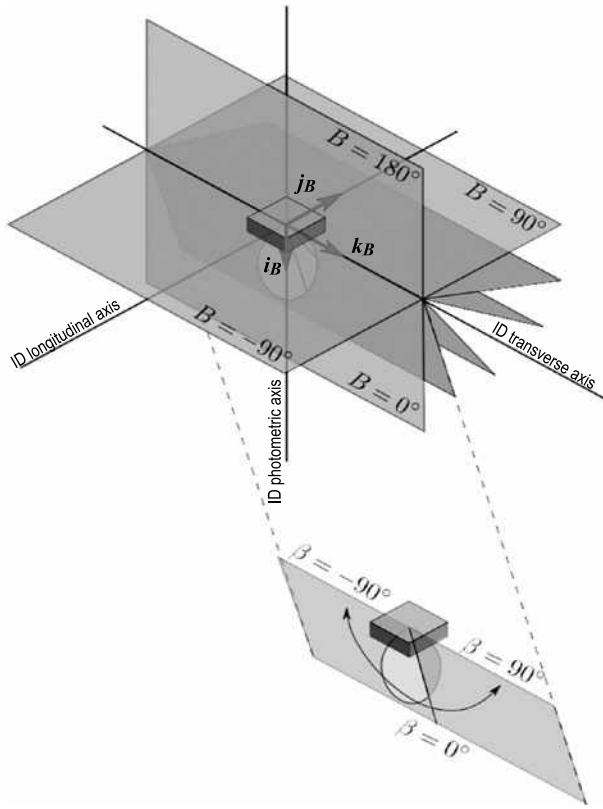

Fig. 3. $B\beta$ photometric system

$$B\beta \rightarrow C\gamma : c = R_{cb}^{-1}b, \quad (5)$$

$$A\alpha \rightarrow B\beta : b = R_{ba}^{-1}a, \quad (6)$$

$$A\alpha \rightarrow C\gamma : c = R_{ca}^{-1}a. \quad (7)$$

Eqns. (2–7) define the relations between the photometric systems. Explicitly solving these equations, we are finding the following angle correlations:

$$C\gamma \rightarrow B\beta : B = \arctg(\sin C \cdot \tg\gamma),$$

$$\beta = \arcsin(\cos C \cdot \sin\gamma), \quad (8)$$

$$B\beta \rightarrow A\alpha : A = \arctg(\tg\beta / \cos B),$$

$$\alpha = \arcsin(\sin B \cdot \cos\beta), \quad (9)$$

$$C\gamma \rightarrow A\alpha : A = \arctg(\cos C \cdot \tg\gamma),$$

$$\alpha = \arcsin(\sin C \cdot \sin\beta), \quad (10)$$

$$B\beta \rightarrow C\gamma : C = \arctg(\sin B / \tg\beta),$$

$$\gamma = \arccos(\cos B \cdot \cos\beta), \quad (11)$$

$$A\alpha \rightarrow B\beta : B = \arctg(\tg\alpha / \cos A),$$

$$\beta = \arcsin(\sin A \cdot \cos\alpha), \quad (12)$$

$$A\alpha \rightarrow C\gamma : C = \arctg(\tg\alpha / \sin A),$$

$$\gamma = \arccos(\cos A \cdot \cos\alpha). \quad (13)$$

These correlations are introduced in [1]. After analysing these correlations according to Figs. 1–4, we conclude that use of the main arctangent line is not enough to find the A equator angle, the B equator angle, and the C equator angle as $-\pi \leq A \leq \pi$, $-\pi \leq B \leq \pi$, $0 \leq C \leq 2\pi$ and $-\pi/2 < \arctg x < \pi/2$. This leads to loss of half data after transition. To reasonable define all meridian angle values you should consider the meridian angle as an argument of a complex number:

In case of A and B , we have

$$\varphi(y, x) = \begin{cases} \arctg(y/x), x > 0; \\ \pi + \arctg(y/x), x < 0, y \geq 0; \\ -\pi + \arctg(y/x), x < 0, y < 0; \\ \pi/2, x = 0, y > 0; \\ -\pi/2, x = 0, y < 0; \end{cases}$$

And in case of C , we have

$$\varphi^*(y/x) = \begin{cases} \arctg(y/x), x > 0, y \geq 0; \\ \pi + \arctg(y/x), x < 0; \\ 2\pi + \arctg(y/x), x > 0, y < 0; \\ \pi/2, x = 0, y > 0; \\ 3\pi/2, x = 0, y < 0. \end{cases}$$

Let us consider this and rewrite Eqns. (8–13) as follows:

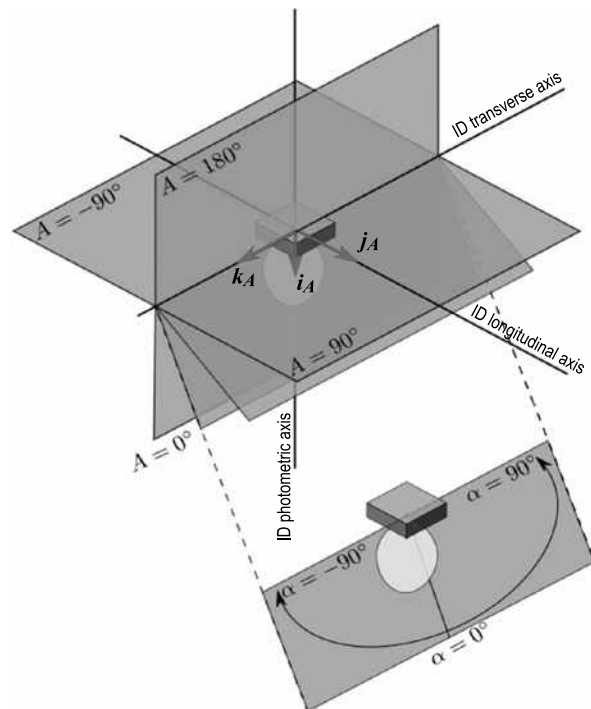

Fig. 4. $A\alpha$ photometric system

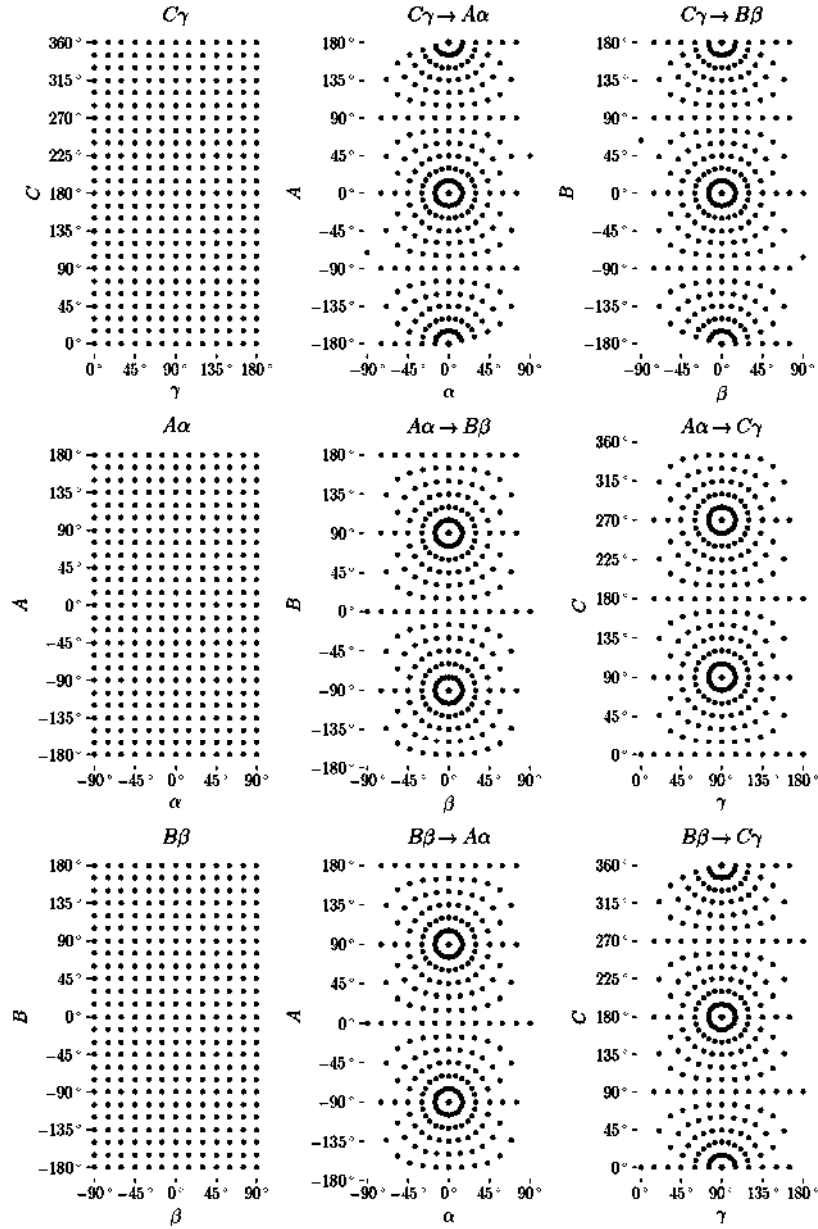

Fig. 5. Photometric systems nodes before and after transition in accordance with Eqns. (14–19)

$$\begin{aligned}
 C\gamma \rightarrow B\beta : B &= \varphi(\sin C, \text{ctg}\gamma), \\
 \beta &= \arcsin(\cos C \cdot \sin \gamma),
 \end{aligned}
 \tag{14}$$

$$\begin{aligned}
 B\beta \rightarrow C\gamma : C &= \varphi(\sin B, \text{tg}\beta), \\
 \gamma &= \arccos(\cos B \cdot \cos \beta),
 \end{aligned}
 \tag{15}$$

$$\begin{aligned}
 B\beta \rightarrow A\alpha : A &= \varphi(\text{tg}\beta, \cos B), \\
 \alpha &= \arcsin(\sin B \cdot \cos \beta),
 \end{aligned}
 \tag{16}$$

$$\begin{aligned}
 A\alpha \rightarrow B\beta : B &= \varphi(\text{tg}\alpha, \cos A), \\
 \beta &= \arcsin(\sin A \cdot \cos \alpha),
 \end{aligned}
 \tag{17}$$

$$\begin{aligned}
 A\alpha \rightarrow C\gamma : C &= \varphi(\text{tg}\alpha, \sin A), \\
 \gamma &= \arccos(\cos A \cdot \cos \alpha),
 \end{aligned}
 \tag{18}$$

$$\begin{aligned}
 C\gamma \rightarrow A\alpha : A &= \varphi(\cos C, \text{ctg}\gamma), \\
 \alpha &= \arcsin(\sin C \cdot \sin \gamma).
 \end{aligned}
 \tag{19}$$

According to the transition result (Fig. 5), the data structure becomes a non-regular structure after transpositions as per Eqns. (14–19), and we need additional interpolation of luminous intensity values. There are 2 alternatives:

- If we combine the old system (source data system) with the new system, luminous intensity values are then interpolated in the new system. Interpolation nodes form a non-regular grid, and this is the reason why you should use appropriate interpolation (e.g. Delaunay triangulation) [4];

• If we combine the new system (where we want to get luminous intensity values) with the old system, luminous intensity values are then interpolated in the old system. Interpolation nodes form a rectangular grid, and this is the reason why you can use bilinear interpolation to find luminous intensity values [5].

This article introduces a transition method between photometric systems based on their combination by means of rotations in the Cartesian coordinate system and on subsequent interpolation of luminous intensity values in given nodes. Unlike the formulas given in [2], Eqns. (14–19) allow us to reasonably define all meridian angle values in the area of taken values: $[-\pi, \pi]$ for A and B , and $[0, 2\pi]$ for C . After transposition in Eqns. (14–19), the angle grid becomes a non-regular grid that prevents exporting files to LDT and IES which are widely used photometric data formats [6, 7]. It is found that [2] for $A\alpha \rightarrow C\gamma$ does not give any equation that could conform to either [1] or the solution given in this article. According to [2], $A\alpha \rightarrow C\gamma$ is transited as follows:

$$\gamma = \alpha + 90^\circ, C = \begin{cases} -A, & -180^\circ < A < 0^\circ; \\ 360^\circ - A, & 0^\circ < A < 180^\circ; \\ 0^\circ, 360^\circ, & A = 0^\circ. \end{cases} \quad (20)$$

According to the analysis of Eqn. (20), there is no rotation of $A\alpha$ relative to the ID before it combines with $C\gamma$. This means that the polar axis of $C\gamma$ (photometric semi-planes intersection line) does not combine with the optical axis of the ID after transition in Eqn. (20), which infringes one of the requirements for given system building [1, 2].

REFERENCES

- GOST R54350–2015. Illumination Devices. Lighting Specifications and Testing Methods.
- GOST R54350–2015. Pribory osvetitelnyye. Svetotekhnicheskiye trebovaniya i metody ispytaniy.
- IESNA LM-75–01. Goniophotometer Types and Photometric Coordinates.
- Alekseevsky, D. V., Vinberg, E. B., Solodovnikov, A.S. Constant Curvature Space Geometry // Science and Engineering Results. Modern Mathematics Challenges. Fundamental Directions. Moscow: VINITI, 1988, Vol. 29, pp. 1–146.
- Skvortsov, A.V. Delaunay Triangulation and Its Use. Tomsk: Tomsk University Press, 2002, 128 p.
- Skvortsov, A.V. Triangulyatsiya Delone i yeye primeneniye. – Tomsk: Izd-vo Tomskogo un-ta, 2002, 128 p.
- GOST R55708–2013. Outdoor Utility Lighting. Rate Parameters Calculation Methods.
- GOST R55708–2013. Osveshcheniye naruzhnoye utilitarnoye. Metody rascheta normiruyemykh parametrov.
- IESNA: LM-63–1995. Standard File Format for Electronic Transfer of Photometric Data.
- Stockmar, A. W. EULUMDAT/2 – Extended Version of a Well Established Luminaire Data Format // CIBSE National Lighting Conference, 1998, pp. 353–362.



Olga E. Zheleznikova,
Ph.D. in Technical Science,
Assistant Professor,
graduated from the Ogarev
Mordovia State University
in 1989, the Faculty for
Lighting Engineering. She
is now the Head of the

Chair for Lighting Engineering at the National Research University – the Ogarev Mordovia State University. She is also an Honorary Figure of Mordovian Higher Education and a Member of the Editorial Board of Light & Engineering Journal



Sergei V. Prytkov,
Ph.D. in Technical Science,
graduated from the Ogarev
Mordovia State University
in 2010. He is now the
Assistant Professor of
the Lighting Engineering
Faculty at the National

Research University – the Ogarev Mordovia State University. Field of his interests includes lighting design