

## DAYLIGHT IN UNDERGROUND SPACES

Alexei K. Solovyev

*Moscow state scientific-research University for Civil Engineering,  
Department of buildings and structures design  
E-mail: agpz@mgsu.ru*

---

### ABSTRACT

Underground spaces in town centres present a big attraction for investors. However, they put special requirements to the internal environment. Those requirements can be fulfilled by means of daylighting. Examples of lighting of underground spaces are discussed. It is shown that the common systems of natural lighting are not always possible to use and cause big heat losses. Hollow light guide pipes allow avoid the shortcomings of common daylight systems. Method of calculation of daylight factors from hollow light guide pipes is shown. The results of calculation of daylight factors under the light guide pipes of different diameters in the different depths are presented.

**Keywords:** underground space, daylighting, hollow light guide pipes, daylight factor

### INTRODUCTION

Subsoil surfaces of cities attach growing importance in the architecture. In the Central districts of cities territories are fully developed. Any open areas are an invaluable urban element that attracts people's attention, allows them safely explore the adjacent buildings go for a walk in centre. At the same time, the underground space in such areas is attractive for investors allowing them to use it as a shopping and leisure area, restaurants, shops, services, etc. However, urban underground space is put special requirements to the internal environment. People under the ground should feel comfortable and

safe and, if possible, not to lose touch with the external environment.

### EXAMPLES OF UNDERGROUND SPACES

The most known in Russia example of such underground spaces is the subsoil shopping Mall on Manezh square "Okhotny Ryad" in Moscow. A three-level underground complex has input knots in the form of atriums, covered with large translucent domes. One of these domes has a diameter of about 20 m (Fig.1). The dome illuminates with natural light the central hall having three levels of underground space. At the same time, restaurants and cafes under balconies of the atrium are lit by permanent lighting systems of artificial light. The changing levels of natural illumination create the natural dynamics of light. All the underground shops flank-



Fig.1. The dome of the central hall of the trading complex "Okhotny Ryad"



Fig.2. Ground planning of the Manezh square

ing a Central atrium and corridors connecting the input nodes are lit by artificial light. Lighting dynamics, inherent to natural light, there is absent.

The corridors, at least at the first underground level, could be lit with natural light using a band roof lights. Stores could have natural light through a hollow tubular light guides (HLTG) [1,2,3]. The light guides could serve the natural light to illuminate the second and third underground levels of shops. This, of course, require necessity to reorganize the ground planning the Manezh square (Fig.2) to make room for the upper parts of skylights and the light receiving devices of tubular light guides which can be obstacle considering the main recreational purpose of the ground area of the Manezh square. Such reconstruction in the future would be possible. The conduct of natural light into the underground space would enhance the comfort and sense of safety in the underground space. The monotony and continuous spectrum of artificial light will be broken by the dynamics of levels and spectrum of natural light. Visitors will feel minimal necessary connection with the outside environment, feel the time of day and weather condition.

Another example of using natural light to illuminate the underground space is the hub of Flint Holm in Copenhagen (Denmark), bringing together metro, ring railway, and the railway station leading to Frederikssund. Six platforms are located under a glass roof with a size of 180 to 60m. As a result, all station is lit by natural light. Two stations are located at bridges. Station on lines passing in the transverse direction, are arranged on the lower bridge level. Even lower is the bus station [4].

On the structure that is above a glass roof, artificial light systems are mounted. Therefore, they can



Fig.3. Entrance zone in tube, Kopenhagen (Photo of Peter Bartenbach)

be easily serviced without disturbing the movement of trains. To provide a warm light with a colour temperature of 3000 K halogen light sources are applied. The main artificial lighting is provided by using the LEDs strip with a length of 2.5 km, illuminating in the dark and in cloudy weather the sub-surface and steel structures of the hub.

The project of natural and artificial lighting of this major interchange hub and all the new metro in Copenhagen are created by the engineering bureau of Bartenbach (Switzerland) – light laboratory “Light underground”. In the new metro stations, the designers have tried to avoid twilight corners, turning a dark and dirty metro station in the bright rooms partly lit with natural light. If the passengers earlier felt the strain, approaching the dark entrance to the tube escalators, now in the input zones is created a pleasant atmosphere of natural light (Fig.3). At the same time, people feel the changing weather situation outside. In the morning there is cool natural light with a colour temperature of about 6500K, and warmer light with a colour temperature of 4500K in the evening. All this has provided communication with the external environment and increased feeling of safety underground. People, located at the metro station, can immediately feel the outside, whether outside shines the sun or the sky is covered with clouds.

Natural light in the station is served, usually, through skylights. To increase their effectiveness, the sidewalls of the skylights shafts are lined with pure aluminium and allow to deliver natural light at the depth of metro stations without big losses like



Fig. 4. Sunlight spectral components on the wall of the tube escalator, Copenhagen (Photo of Peter Bartenbach)

light pipes. However, it should be noted, that in case of a large section of the shafts, which are characteristic to the roof skylights, to create a mirror surface of the shaft, like this takes place in the tubes of the light guides, is a very difficult and a very expensive task. Therefore, it is impossible to compare the effectiveness of these devices.

The movement of the sun is transmitted into the room using glass prisms, mounted in skylights. Prisms are decomposing sunlight into spectral components. This creates pictures on the walls like rainbows that move around the surface of the input knots and escalators (Fig.4).

### LIGHTING OF UNDERGROUND SPACES BY USING HOLLOW TUBULAR LIGHT GUIDES

The examples show that for not deep underground spaces of the city it is possible and useful to illuminate the space using different systems of natural light. The conventional systems in the form of skylights and translucent coverings provide a lot of light, but have disadvantages.

First of all, roof lights and translucent coverings require the use of large urban areas, which can no longer be used as recreational zones.

Secondary, skylights and other translucent structures create a large heat loss in winter and in summer they create heat gains in the underground spaces of the city that need to be neutralized with significant expenditures of energy.

The use of hollow tubular light guides reduces these disadvantages [1,2,3]. The area, occupied by the receiving elements of the tubular light guides is considerably less. The heat gains through the light guide are also many times smaller [5]. At the same time, the light guides retain such advantages of natural lighting as the natural light spectrum and its dynamics depending on time of day and weather.

The evaluation of natural light through light guides as well as from the usual light openings can be made with the help of Daylight Coefficient (DK). Thus, in the calculation of duration of natural lighting it can be used not the diffuse illumination from the sky, but the total illuminance from sky and sun.

Coefficient of performance ( $\eta$ ) of the light guide system is determined by the formula:

$$\eta = \tau_c \times \tau_d \times K_m \times \xi, \quad (1)$$

where  $\tau_d$  – light transmission of the diffuser: for example, by the Italian system SOLARSPOT  $\tau_d = 0.8$ ;  $\tau_c$  – light transmittance of the outer dome of the light guide, its rim and the intermediate lenses. By the SOLARSPOT system  $\tau_c = 0.92$ ;  $K_m$  – the safety factor (takes into account the pollution of the dome during operation, J. Bracale  $K_m = 0.92$ ) [1];  $\xi$  – is the efficiency of the pipe of a hollow straight light guide. It depends on the reflection coefficient of the mirror coatings of the pipe of the light guide  $\rho$ , the ratio length of the light guide to diameter of the tube ( $L/D$ ), i.e. the number of reflections of light rays inside the tube and the angle  $\theta$  of the rays falling on the dome of the light guide, to its axis.  $\theta$  is most easily defined for the direct component of solar light. In vertical position the axis of the light guide, it is equal to the Zenith distance of the sun in a given time. I.e. efficiency varies depending on the height of the sun. The average efficiency of the fibre is well represented by the CIE cloudy sky. In this case  $\theta = 30^\circ$ . This value is proposed to calculate  $\xi$ . The efficiency of the light guide  $\xi$  can be determined according to the simplified formula of multiple reflections [1]:

$$\xi = (e^{L/D} \operatorname{tg} \theta \ln \rho) / [1 - L/D \operatorname{tg} \theta \ln \rho]^{1/2}. \quad (2)$$

This value may also be determined according to the table given in [1 and 7], calculated by the formula (2).

The luminous flux emitted by the diffuser:

$$\Phi_d = \eta \cdot \Phi_{outer} \tag{3}$$

where  $\Phi_{outer}$  – luminous flux included in the light guide outside:

$$\Phi_{outer} = [(180-\theta)/180] \cdot E_h \cdot A, \tag{4}$$

where  $(180-\theta)/180$  – input coefficient of the HLTG;  $A$  is the cross – sectional area of light guide pipe,  $A = \pi \cdot D^2/4$ ;  $E_h$  – illuminance outside on a horizontal platform. If you want to determine the daylight factor (DF) under the HLTG,  $E_h = 100\%$ .

The DF-value under the light guide in point M is determined by the formula:

$$\xi_m = L_d \cdot A/r^2, \tag{5}$$

where  $L_d$  is the luminance of the diffuser;  $L_d = \Phi_d / (\pi \cdot A)$ .

Substituting in the formula (5) the values of  $L_d$  and  $\Phi_d$  (3) we shall receive a calculation formula for calculation DF-value under the light guide.

$$\xi_m = [\eta \cdot D^2 \cdot 0,83] / (4 \cdot r^2) \cdot 100\%, \tag{6}$$

where  $0,83 = (180-30)/180$ ;  $30^\circ$  – the average height of the sun, corresponding to the conditions of a cloudy sky;  $\cos\beta = \cos\gamma = 1$  for our calculation case where the reference point is located directly beneath the light guide;  $r$  is the distance between centre of diffuser and the reference point. For our design case this is the height of the diffuser above the work plane. According to Fig.5 for our calculations  $r = 4\text{m}$ .

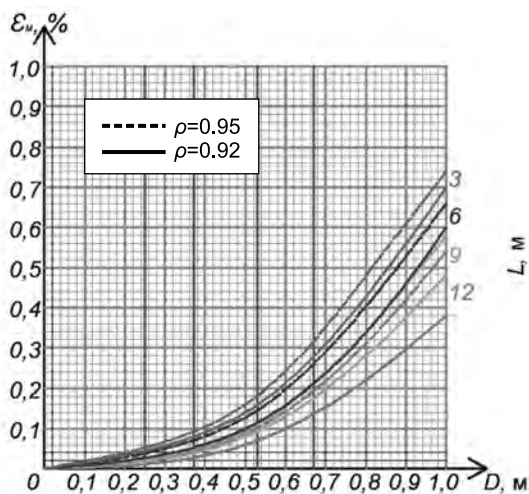

Fig.6. Dependence of DF-value under the light guide in the point M from the diameter of the tube of the light guide

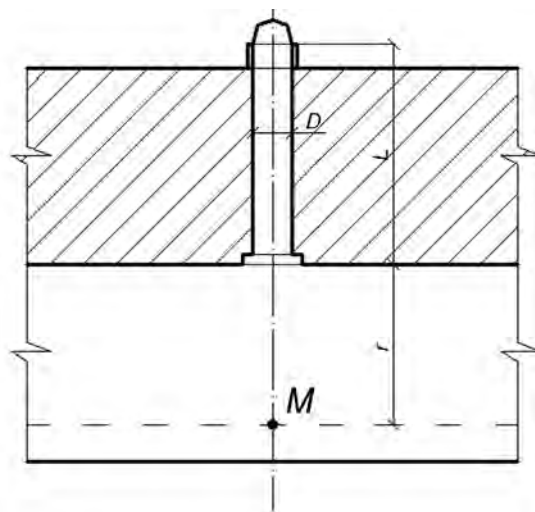

Fig.5. Diagram to the calculation of DF-value under the light guide in point M

The result of the DC-value calculation direct under the right tube of light guide for underground spaces at various depths for different diameters of the light guide and different values of the reflectance of mirror-like inner surface of the pipe are presented in Table 1. All the symbols in Table 1 see formulae (1) and (2), as well as Fig.5. Light transmittance coefficients of the dome and diffuser are taken according to J. Brakale [1].

Dependences of DC-values on the diameter of light guide tube ( $D$ ) by different length of the tube ( $L$ ) are represented in the Fig.6. As it is seen in the Fig.5, the DF-value is growing practically according to the parabola law, depending on the  $D$ -value. The dependence of decrease of  $D$  on the rising of length of the tube ( $L$ ) is smoother (Fig.7). This is

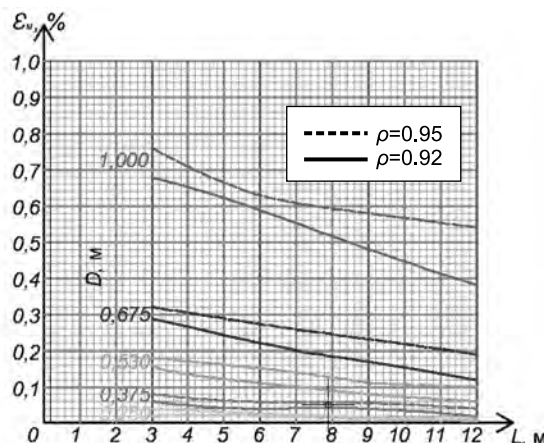

Fig.7. Dependence of DF-value under the light guide in the point M from the depth of the underground space

Table 1. Calculation of DC Under the Direct Waveguide for the SOLARSPOT System

$\rho = 0,92$																	
$D$	$D^2$	L = 3				L = 6				L = 9				L = 12			
		$\frac{L}{D}$	$\xi$	$\eta_d$	$\epsilon_m$	$\frac{L}{D}$	$\xi$	$\eta_d$	$\epsilon_m$	$\frac{L}{D}$	$\xi$	$\eta_d$	$\epsilon_m$	$\frac{L}{D}$	$\xi$	$\eta_d$	$\epsilon_m$
0,25	0,0625	12	0,45	0,31	0,025	24	0,24	0,16	0,013	36	0,15	0,1	0,008	48	0,06	0,04	0,003
0,375	0,1406	8	0,58	0,39	0,072	16	0,35	0,24	0,043	24	0,17	0,11	0,02	32	0,18	0,12	0,02
0,53	0,2809	5,66	0,68	0,46	0,168	11,32	0,46	0,31	0,113	16,98	0,33	0,22	0,08	22,64	0,25	0,17	0,06
0,675	0,4556	4,44	0,73	0,49	0,292	8,88	0,55	0,37	0,22	13,33	0,44	0,3	0,17	17,76	0,31	0,21	0,12
1,0	1,0	3	0,78	0,53	0,684	6	0,67	0,45	0,59	9	0,55	0,37	0,48	12	0,44	0,29	0,38

$\rho = 0,95$																	
$D$	$D^2$	L = 3				L = 6				L = 9				L = 12			
		$\frac{L}{D}$	$\xi$	$\eta_d$	$\epsilon_m$	$\frac{L}{D}$	$\xi$	$\eta_d$	$\epsilon_m$	$\frac{L}{D}$	$\xi$	$\eta_d$	$\epsilon_m$	$\frac{L}{D}$	$\xi$	$\eta_d$	$\epsilon_m$
0,25	0,0625	12	0,61	0,41	0,033	24	0,39	0,26	0,021	36	0,27	0,18	0,015	48	0,16	0,11	0,009
0,375	0,1406	8	0,69	0,47	0,085	16	0,50	0,34	0,062	24	0,39	0,26	0,048	32	0,31	0,21	0,038
0,53	0,2809	5,66	0,76	0,51	0,19	11,32	0,63	0,42	0,155	16,98	0,48	0,32	0,12	22,64	0,40	0,27	0,10
0,675	0,4556	4,44	0,81	0,55	0,32	8,88	0,67	0,46	0,27	13,33	0,58	0,39	0,23	17,76	0,47	0,32	0,19
1,0	1,0	3	0,86	0,58	0,76	6	0,72	0,49	0,63	9	0,67	0,45	0,59	12	0,60	0,41	0,53

explained by the fact that from the diameter of tube and input set of the light guide the light flux value coming into the tube depends. At the same time, only the amount of reflections in it is depending from the length of the tube. The bigger diameter of the tube, the less the amount of reflections will be in it by the same length.

Having obtained the DF-value direct under the light guide it is possible to calculate DF-value in each point of the room either according to Lambert law or by the method given in the Russian norm CII 23–102–2003 as from round light source [6].

It must be noted, that DC-values given in Table 1 and in the Figs.6,7 calculated by means of formulae (1–6) are taken without internal reflection, which can be calculated according to CII 23–102–2003, as for convenient systems of roof lighting. The average DF-values for the whole lit area of the underground space can be calculated as a sum of DF-values in all calculation points of the room from all light guides divided by the amount of calculation points.

## CONCLUSIONS

Subsoil space of a city, there, where it is possible, must be good lit with daylight. It gives to the people confidence, ensuring connection with external environment. But the convenient systems of upper daylight can be applied in not deep underground spaces. What depth is maximal for the effective use of different daylight systems is to be still investigated. Besides it the convenient systems of daylighting require big areas on the surface of the ground, which decrease possibilities of planning free areas and their recreational value. Applications of the light guides for illumination of underground spaces

do not have this shortcoming. Additionally, using of light guides do not have such restrictions to the depth, as the convenient daylighting systems.

As by convenient systems of daylighting, therefore by light guides, the maximal economy of electric energy can be gained only in combination with automatic control of supplementary artificial lighting. For all that from the point of view of daylighting, the light guides of big diameter are more preferable, but it comes in to contradiction with their costs and with increasing of heat gains and heat losses through their constructions.

## REFERENCES

1. Bracale J. Natural lighting of rooms by means of a new passive light guide system “SOLAR-SPOT”. // Svetotekhnika, 2005. No 5, pp.34–42.
2. Solovyev A.K. Hollow tubular light guides: Their application for natural illumination of buildings and energy saving. // Light & Engineering. 2012. V.20. No 1, pp.40–49.
3. Kusnetsov A.L., Oseledets E. Ju., Solovyov A.K., Stolyarov M.V. Experience of application of hollow tubular light guides for natural illumination in Russia. // Light & Engineering. 2012. V.20. No 3, pp.62–70.
4. Tageslicht im Untergrund. Innovative Tageslichtlenkung in der Metro von Kopenhagen. // Tageslicht (Sonderausgabe der Zeitschrift “Licht”. 2004. No 1. pp.8–9.
5. Solovyov A.K., Tushina O.A. Comparative heat calculation of upper daylight systems (skylights and hollow tubular light guides). // Civil engineering journal, 2014, No 2, pp.24–35.
6. Solovyov A.K. Physic of environment. Manual for the specialty “Design of Buildings”. ASV-press. Moscow, 2016, pp.341.



**Alexei K. Solovyov,**

Prof., Dr. of Tech. Sc., had been graduated from MISI named after V.V. Kuibyshev in 1965. At present, he is Professor of the department “Designing buildings and structures “(former department of” Architecture of civil and industrial buildings“), NIU “MSSU”, member of the European Academy of Sciences and the arts and editorial boards of the journals “Svetotekhnika” and “Light & Engineering”, has the title of “Honorary Builder of the Russian Federation” and “Honoured Worker of the Higher School of Russia”